

LEGENDA:

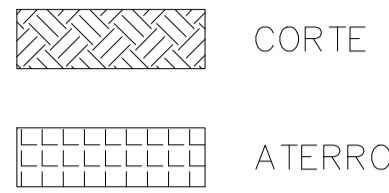

PERFIL EIXO 1.per

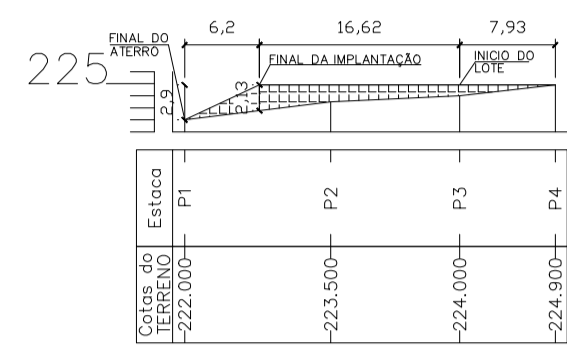

ATERRO

PERFIL EIXO 2.per

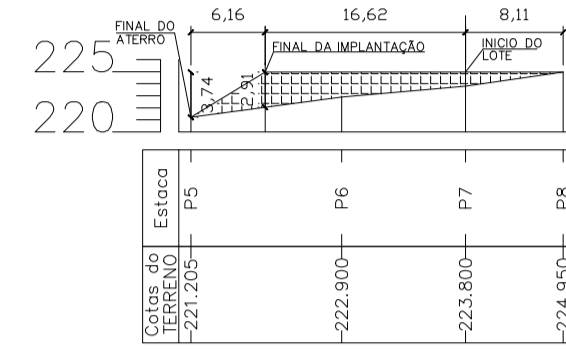

ATERRO

PERFIL EIXO 3.per

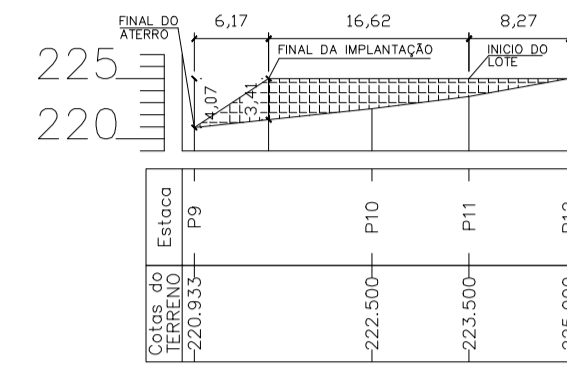

ATERRO

PERFIL EIXO 4.per

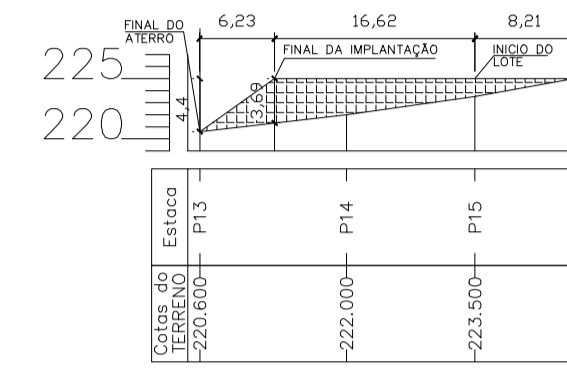

ATERRO

PERFIL EIXO 5.per

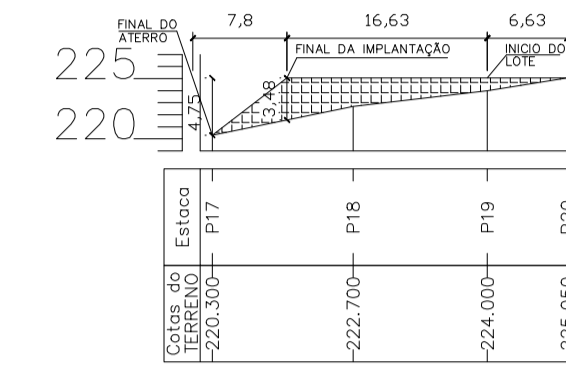

ATERRO

PERFIL EIXO 6.per

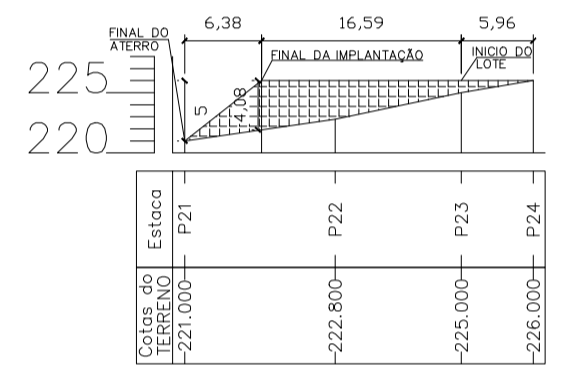

ATERRO

PERFIL EIXO 7.per

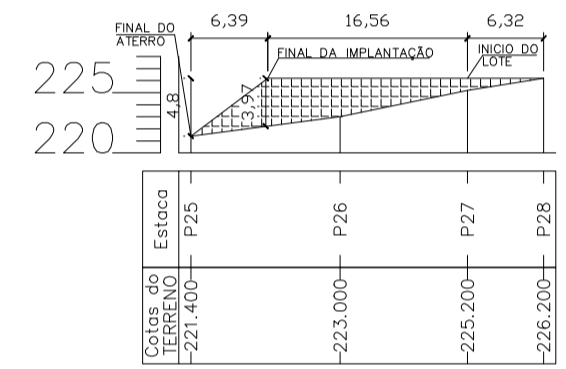

ATERRO

PERFIL EIXO 8.per

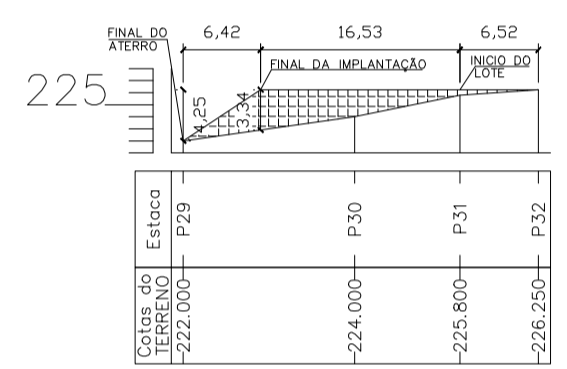

ATERRO

PERFIL EIXO 9.per

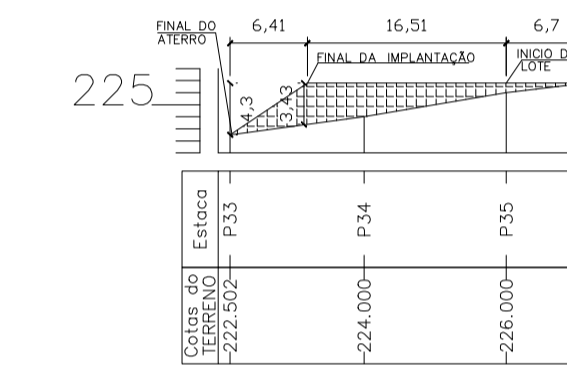

ATERRO

PERFIL EIXO 10.per

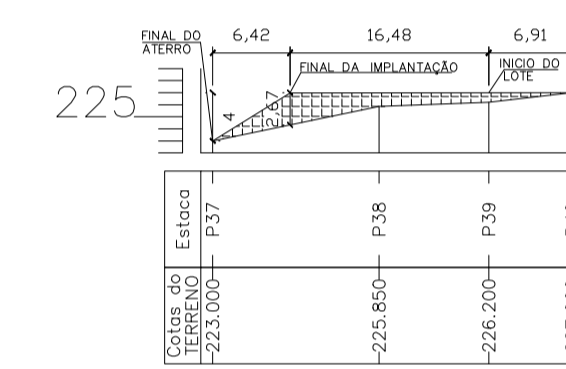

ATERRO

PERFIL EIXO 11.per

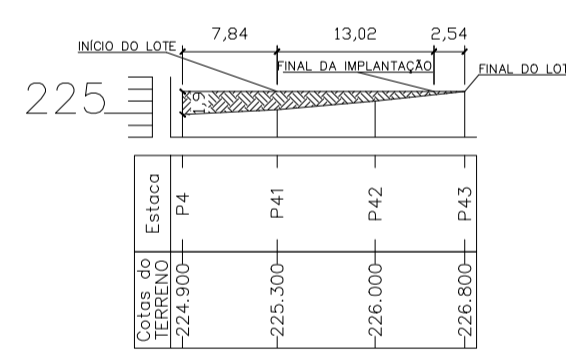

CORTE

PERFIL EIXO 12.per

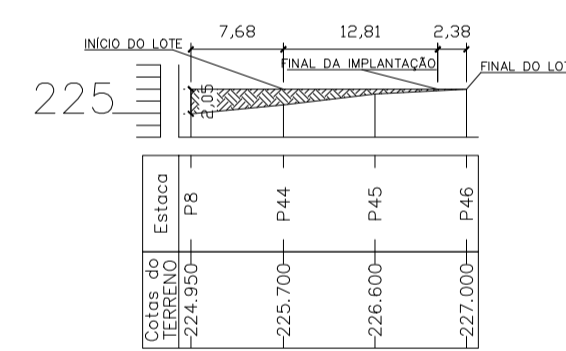

CORTE

PERFIL EIXO 13.per

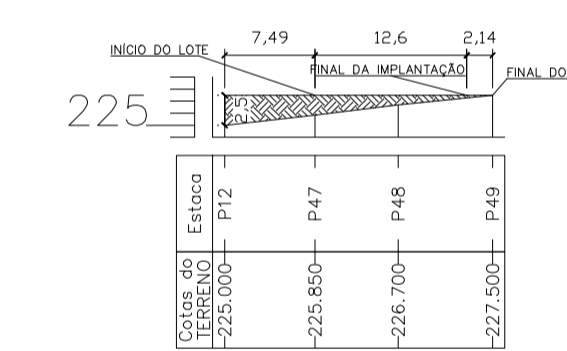

CORTE

PERFIL EIXO 14.per

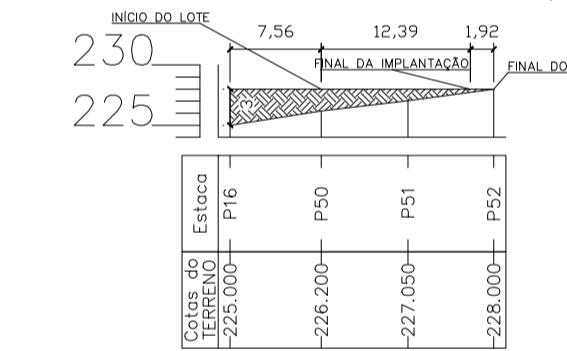

CORTE

PERFIL EIXO 15.per

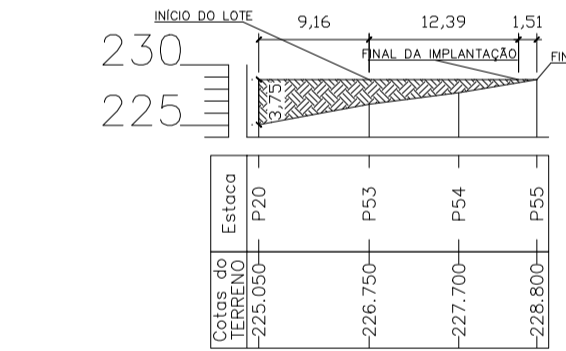

CORTE

PERFIL EIXO 16.per

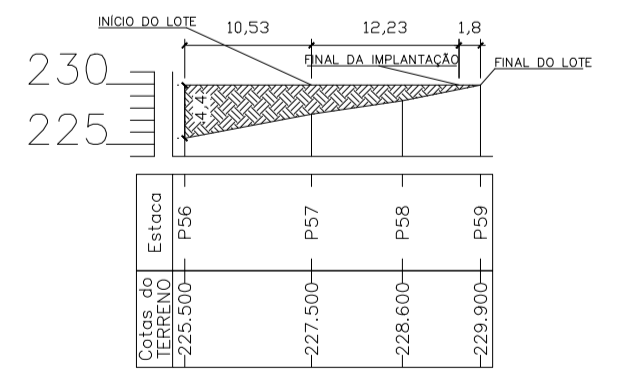

CORTE

PERFIL EIXO 17.per

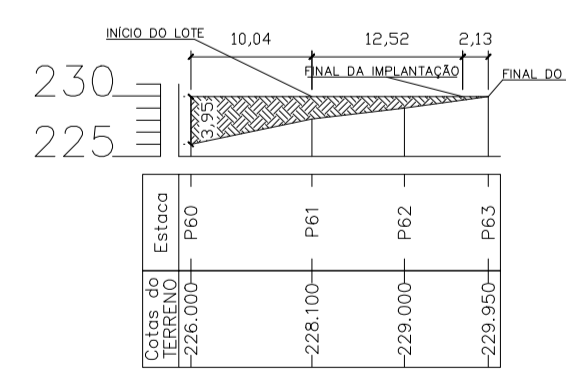

CORTE

PERFIL EIXO 18.per

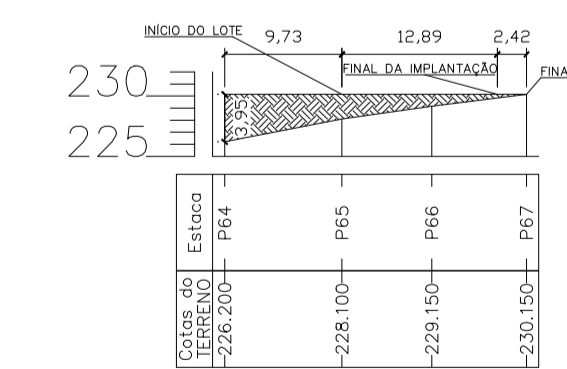

CORTE

PERFIL EIXO 19.per

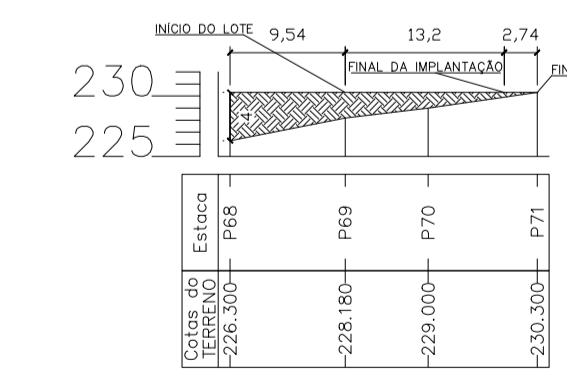

CORTE

PERFIL EIXO 20.per

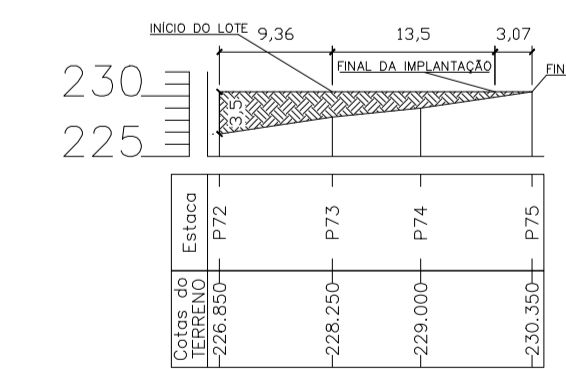

CORTE



PROJETO LOTEAMENTO CIDADE FELIZ PAVÃO/MG

CIDADE PAVÃO ESTADO MINAS GERAIS FEDERAÇÃO BRASIL

ENDEREÇO LOTEAMENTO MUNICIPAL CIDADE FELIZ, BAIRRO PLANALTO, PAVÃO/MG

REFEITURA MUNICIPAL DE PAVÃO

CHRYSSTIAN SILVA ANDRADE:10826014623
 CHRYSTIAN SILVA ANDRADE
 CREA: BA-50815/D MG
 ENGENHEIRO CIVIL

FASE PROJETO EXECUTIVO OBJETO ESCALA S/ESCALA DIMENSÃO DA FOLHA A1

PERFIL CORTE E ATERRO

ART: MG20254369524
 N° OPERAÇÃO: 1103566-07
 N° TRANSFEREGOV: 39726/2025

M² PROJETO ARQUITETÔNICO 53,87 M²
 M² ÁREA DOS LOTES 3.781,22 M²
 M² LOTEAMENTO 1.077,40 M²
 DATA 26/11/2025
 ARQUIVO DIGITAL LOTEAMENTO CIDADE FELIZ